

25-140-1
14 INCH TURNPLATE GAUGE

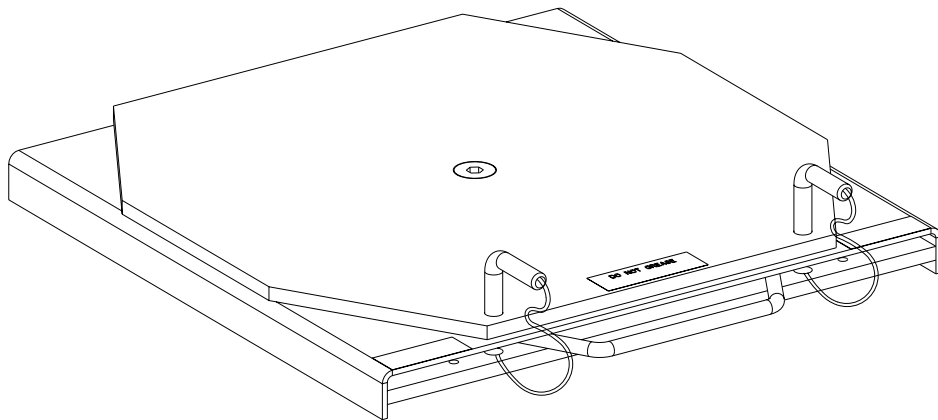

25-140-1 14 INCH TURNPLATE GAUGE
REFER TO NEXT SHEET FOR PARTS DESCRIPTION LISTING

PARTS DESCRIPTION LISTING

Form 7-42, 10-99
Sheet 2 of 3

Part Number	Description
25-140-1	14 INCH TURNPLATE GAUGE

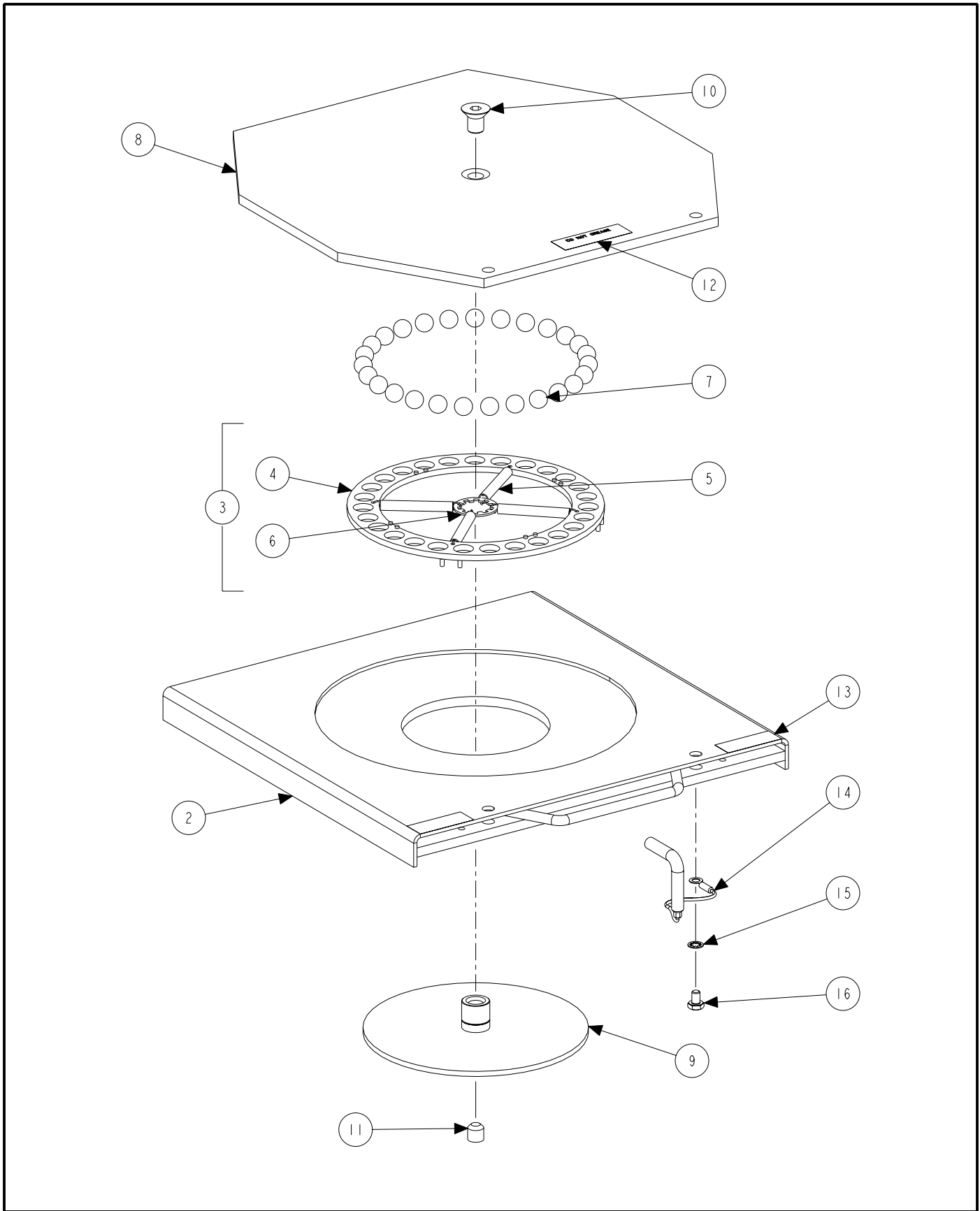

25-140-1 14 INCH TURNPLATE GAUGE
REFER TO NEXT SHEET FOR PARTS DESCRIPTION LISTING

Index No	Part Number		Qty
1	25-140-1	14 INCH TURNPLATE GAUGE (Consistng Of:)	1
2	51-1753-1-PPP	PLATE, TURNPLATE BASE WELDMENT	1
3	41-43-1	RETAINER, TURNPLATE (Consisting Of:)	1
4	41-65-2	RETAINER, BALL BEARING 14 INCH	1
5	WA90-16	WASHER, PLAIN 7/8 #1234 SHAKEPROOF	1
6	WA90-10	PENETRATED SPRING	4
7	130-65-2	BEARING, 9/16 GROUND DELRIN 500 P	27
8	51-34-PPP	PLATE, TURN	1
9	51-1754-1-PPP	PLATE, SLIDE	1
10	75-38-2	FLAT HEAD SOCKET CAP SCREW 1/2-20 x .75	1
11	75-39-2	SOCKET SET SCREW 1/2-20 x 1/2 FLAT	1
12	WA90-17	DECAL	1
13	128-571-2	DECAL, PIN TURN/SLIP PLATE	2
14	135-208-2	PIN, LOCK WITH CABLE	2
15	77-13-2	WASHER, LOCK 1/4 INT TOOTH	2
16	75-41-2	HEX HEAD CAP SCREW 1/4-20 x .38	2